

Incremental encoders

With blind or through hollow shaft

1...65536 pulses per revolution programmable

EIL580P - hollow shaft



EIL580P with blind hollow shaft

Features

- Size $\varnothing 58$ mm
- Precise optical sensing
- Output signal level programmable (TTL or HTL)
- Blind or through hollow shaft, $\varnothing 8...15$ mm
- Connection axial, radial or tangential
- Pulses per revolution 1...65536, programmable
- High protection up to IP 67
- High resistance to shock and vibrations

Technical data - electrical ratings

Voltage supply	4.75...30 VDC
Reverse polarity protection	Yes
Short-circuit proof	Yes
Consumption w/o load	≤ 70 mA
Initializing time	≤ 30 ms after power on
Pulses per revolution	1...65536
Scan ratio	45...55 % typical at 2048 ppr
Reference signal	Zero pulse 90° or 180°
Sensing method	Optical
Output frequency	≤ 300 kHz (TTL) ≤ 160 kHz (HTL)
Output signals	A+, B+, R+, A-, B-, R-
Output stages	TTL/RS422 HTL/push-pull
Programmable parameters	Output level TTL/HTL Pulse number 1...65536 Zero pulse width $90^\circ/180^\circ$ Zero pulse position Signal sequence
Interference immunity	DIN EN 61000-6-2
Emitted interference	DIN EN 61000-6-3
Approval	UL 508 / CSA 22.2

Technical data - mechanical design

Size (flange)	$\varnothing 58$ mm
Motor shaft tolerance	0.2 mm axial 0.03 mm radial
Protection DIN EN 60529	IP 65 (without shaft seal), IP 67 (with shaft seal)
Starting torque	≤ 0.02 Nm ($+20^\circ\text{C}$, IP 65) ≤ 0.025 Nm ($+20^\circ\text{C}$, IP 67)
Materials	Housing: aluminium die-cast Flange: aluminium
Operating temperature	$-40...+100^\circ\text{C}$
Relative humidity	90 % non-condensing
Resistance	DIN EN 60068-2-6 Vibration 30 g, 10-2000 Hz DIN EN 60068-2-27 Shock 250 g, 6 ms
Connection	Flange connector M12, 8-pin Flange connector M23, 12-pin Cable
Weight approx.	300 g

EIL580P - blind hollow shaft

Shaft type	$\varnothing 8...15$ mm (blind hollow shaft)
Operating speed	≤ 6000 rpm ($+20^\circ\text{C}$, IP 67) ≤ 8000 rpm ($+20^\circ\text{C}$, IP 65)

EIL580P - through hollow shaft

Shaft type	$\varnothing 8...15$ mm (through hollow shaft)
Operating speed	≤ 3000 rpm ($+20^\circ\text{C}$, IP 67) ≤ 6000 rpm ($+20^\circ\text{C}$, IP 65)

Incremental encoders

With blind or through hollow shaft

1...65536 pulses per revolution programmable

EIL580P - hollow shaft

Part number

Blind hollow shaft

EIL580P- **B** . . . **F** . **01024** . **B**

Operating temperature
B -40...+100 °C

Pulses programmable
01024 1...65536 programmable (factory setting: 1024)

Voltage supply / output stages
F 4.75...30 VDC, TTL/RS422, 6 channels (Vout = 5 VDC) - Factory setting
HTL/push pull 6 channel (Vout = Vin) - programmable by customer

Connection

- R Cable radial, 1 m**
- L Cable radial, 2 m
- F Flange connector M23, 12-pin, radial, male, ccw**
- B Flange connector M12, 8-pin, radial, male, ccw
- T Cable axial, 1 m
- U Cable axial, 2 m
- D Flange connector M23, 12-pin, axial, male, ccw
- A Flange connector M12, 8-pin, axial, male, ccw
- P Cable tangential, 1 m *
- Q Cable tangential, 2 m *

Protection

- 5 IP 65**
- 7 IP 67

Specification hollow shaft

- | | |
|---|---|
| 08 ø8 mm, clamping ring at A side | U4 ø1/2" (12.7 mm), clamping ring at A side |
| U3 ø3/8" (9,52 mm), clamping ring at A side | 14 ø14 mm, clamping ring at A side |
| 10 ø10 mm, clamping ring at A side | 15 ø15 mm, clamping ring at A side |
| 12 ø12 mm, clamping ring at A side | |

Flange

- N Without stator coupling
- T With stator coupling ø63 mm**
- P Torque pin 3 mm, axial/radial

Shaft type

- B Blind hollow shaft

Printed in **bold** = standard items (up to the quantity of 10 will be supplied within 5 working days).

* only available in protection 5 = IP 65

(Factory setting: 1024 ppr, Vout = 5 VDC TTL, signal sequence A leading B (CW), zero pulse 90° A&B high)

Stock items

EIL580P-BT12.5FF.01024.B | EIL580P-BT14.5FF.01024.B

Numerous stock items in single quantity will be supplied within 24 hours respectively one day ex works.

Incremental encoders

With blind or through hollow shaft

1...65536 pulses per revolution programmable

EIL580P - hollow shaft

Part number

Through hollow shaft

EIL580P- T . . . F . 01024 . B

Operating temperature
B -40...+100 °C

Pulses programmable
01024 1...65536 programmable (factory setting: 1024)

Voltage supply / output stages
F 4.75...30 VDC, TTL/RS422, 6 channels (Vout = 5 VDC) - Factory setting
HTL/push pull 6 channel (Vout = Vin) - programmable by customer

Connection

- R Cable radial, 1 m**
- L Cable radial, 2 m
- F Flange connector M23, 12-pin, radial, male, ccw**
- B Flange connector M12, 8-pin, radial, male, ccw
- P Cable tangential, 1 m *
- Q Cable tangential, 2 m *

Protection

- 5 IP 65**
- 7 IP 67

Specification hollow shaft

- | | |
|---|---|
| 08 ø8 mm, clamping ring at A side | 15 ø15 mm, clamping ring at A side |
| U3 ø3/8" (9,52 mm), clamping ring at A side | V3 ø3/8" (9,52 mm), clamping ring at B side |
| 10 ø10 mm, clamping ring at A side | B0 ø10 mm, clamping ring at B side |
| 12 ø12 mm, clamping ring at A side | B2 ø12 mm, clamping ring at B side |
| U4 ø1/2" (12.7 mm), clamping ring at A side | V4 ø1/2" (12.7 mm), clamping ring at B side |
| 14 ø14 mm, clamping ring at A side | B4 ø14 mm, clamping ring at B side |

Flange

- N Without stator coupling
- T With stator coupling ø63 mm**
- P Torque pin 3 mm, axial/radial

Shaft type

- T Through hollow shaft

Printed in **bold** = standard items (up to the quantity of 10 will be supplied within 5 working days).

* only available in protection 5 = IP 65

(Factory setting: 1024 ppr, Vout = 5 VDC TTL, signal sequence A leading B (CW), zero pulse 90° A&B high)

Stock items

EIL580P-TT12.5FF.01024.B | EIL580P-TT14.5FF.01024.B

Numerous stock items in single quantity will be supplied within 24 hours respectively one day ex works.

Incremental encoders

With blind or through hollow shaft

1...65536 pulses per revolution programmable

EIL580P - hollow shaft

Accessories

Connectors and cables

10127844	Connection cable 2 m shielded with female connector M12, 8-pin, straight (ESG 34FH0200G)
10129332	Connection cable 5 m shielded with female connector M12, 8-pin, straight (ESG 34FH0500G)
10129333	Connection cable 10 m shielded with female connector M12, 8-pin, straight (ESG 34FH1000G)
11053961	Connection cable 2 m shielded with female connector M12, 8-pin, angled (ESW 33FH0200G)
11053962	Connection cable 5 m shielded with female connector M12, 8-pin, angled (ESW 33FH0500G)
10170054	Connection cable 10 m shielded with female connector M12, 8-pin, angled (ESW 33FH1000G)
10164705	Connector M23, 12-pin
11095302	Connection cable 1 m shielded with female connector M23, 12-pin
11100408	Connection cable 2 m shielded with female connector M23, 12-pin
11100430	Connection cable 5 m shielded with female connector M23, 12-pin
11100431	Connection cable 10 m shielded with female connector M23, 12-pin
11119280	Connection cable connector M12 / connector D-SUB, 0.2 m
11119720	Connection cable connector M12 / connector D-SUB, 1 m
11119257	Connection cable connector M23 / connector D-SUB, 0.2 m (S2BG12/K4SG9)
11119723	Connection cable connector M23 / connector D-SUB, 1 m (S2BG12/K4SG9)

Mounting accessories for EIL580P - blind hollow shaft

11066081	Torque arm, 1-arm, bolt circle ø82 mm, mounting M4 (mounting kit 003)
11066083	Torque arm, 1-arm, bolt circle ø74...94 mm, mounting M4/M5 (mounting kit 006)
11073119	Torque arm, 1-arm, bolt circle ø65.5...281 mm, mounting M4, can be cut to length (mounting kit 021)
11067367	Torque arm, 1-arm, bolt circle ø74...94 mm, mounting M6 (mounting kit 028)
11113210	Torque arm, 1-arm, bolt circle ø63...94 mm, mounting M4 (mounting kit 047)
11100198	Stator coupling, 2-armed, bolt circle ø63 mm, mounting M3 (mounting kit 046)

Mounting accessories for EIL580P - blind hollow shaft

11106627	Fan cover clip 8 mm
11094674	Clamping ring 12/31/ 8 M3 8.8 for EIL580 hollow shaft ø8...10 mm for clamping at A or B side
11094675	Clamping ring 17/31/ 8 M3 8.8 for EIL580 hollow shaft ø12...15 mm for clamping at A side

Mounting accessories for EIL580P - through hollow shaft

11066081	Torque arm, 1-arm, bolt circle ø82 mm, mounting M4 (mounting kit 003)
11066083	Torque arm, 1-arm, bolt circle ø74...94 mm, mounting M4/M5 (mounting kit 006)
11073119	Torque arm, 1-arm, bolt circle ø65.5...281 mm, mounting M4, can be cut to length (mounting kit 021)
11067367	Torque arm, 1-arm, bolt circle ø74...94 mm, mounting M6 (mounting kit 028)
11113210	Torque arm, 1-arm, bolt circle ø63...94 mm, mounting M4 (mounting kit 047)
11100198	Stator coupling, 2-armed, bolt circle ø63 mm, mounting M3 (mounting kit 046)
11106627	Fan cover clip 8 mm
11094674	Clamping ring 12/31/ 8 M3 8.8 for EIL580 hollow shaft ø8...10 mm for clamping at A or B side
11094675	Clamping ring 17/31/ 8 M3 8.8 for EIL580 hollow shaft ø12...15 mm for clamping at A side
11123483	Clamping ring 16/31/ 8 M3 8.8 for EIL580 hollow shaft ø12...14 mm for clamping at B side

Programming accessories

11120657	Handheld Programming Tool Z-PA-EI-H
11120547	PC Programming Tool Z-PA-EI-P

Incremental encoders

With blind or through hollow shaft

1...65536 pulses per revolution programmable

EIL580P - hollow shaft

Output signals

Zero pulse electrical 90° A&B high
(Factory setting at clockwise rotation (CW)
in view of the encoder flange)

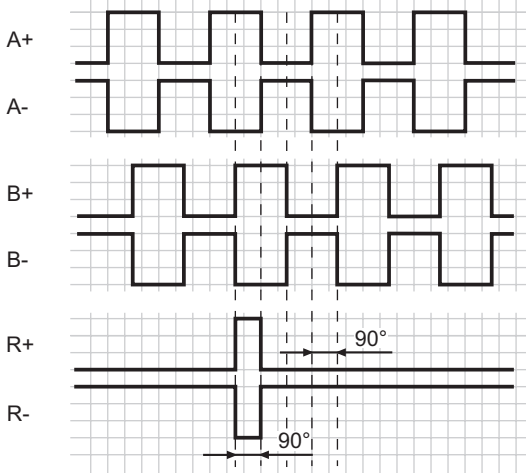

Zero pulse electrical 180° B low
(at clockwise rotation (CW)
in view of the encoder flange)

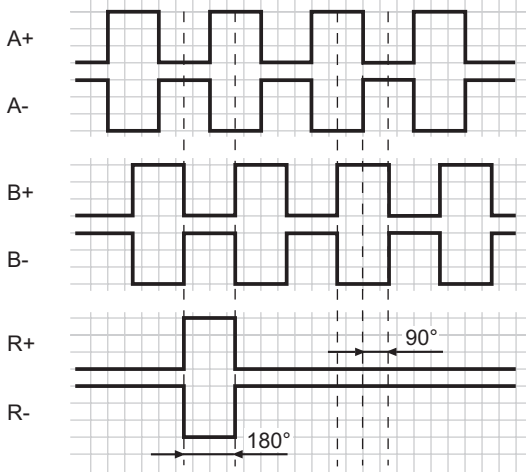

Trigger level

Outputs	TTL/RS422
Output level High	≥2.5 V
Output level Low	≤0.5 V
Load	≤20 mA

Outputs	HTL/Push-pull
Output level High	≥UB -3 V
Output level Low	≤1.5 V
Load	≤20 mA

Terminal assignment

Flange connector M23, 12-pin / cable

Pin	Core color	Assignment
1	pink	B-
2	–	–
3	blue	R+
4	red	R-
5	green	A+
6	yellow	A-
7	–	R-Teach ¹⁾
8	grey	B+
9	–	–
10	white	GND
11	–	–
12	brown	UB

Screen: Connected to housing

Cable data: PUR, [4x2x0,14 mm²], bending radius >45,8 mm, outer diameter 6.1 mm

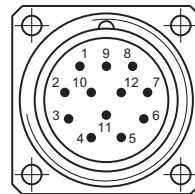

¹⁾ The R-Teach input is used to set the reference pulse (zero pulse) on the current shaft position.
R-Teach = UB ≥ 200 ms

Flange connector M12, 8-pin

Pin	Assignment
1	GND
2	UB
3	A+
4	A-
5	B+
6	B-
7	R+
8	R-

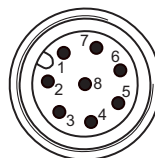

Incremental encoders

With blind or through hollow shaft
1...65536 pulses per revolution programmable

EIL580P - hollow shaft

Dimensions

Clamping ring at A-side:
Blind hollow shaft, flange connector M12 radial

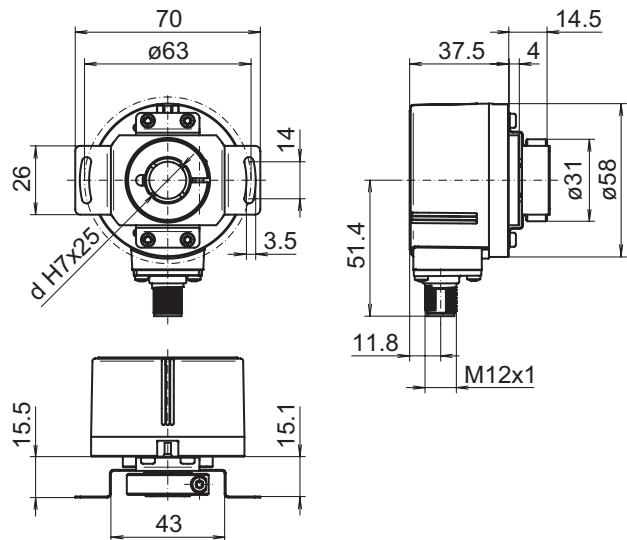

Clamping ring at A-side:
Blind hollow shaft, flange connector M12 axial

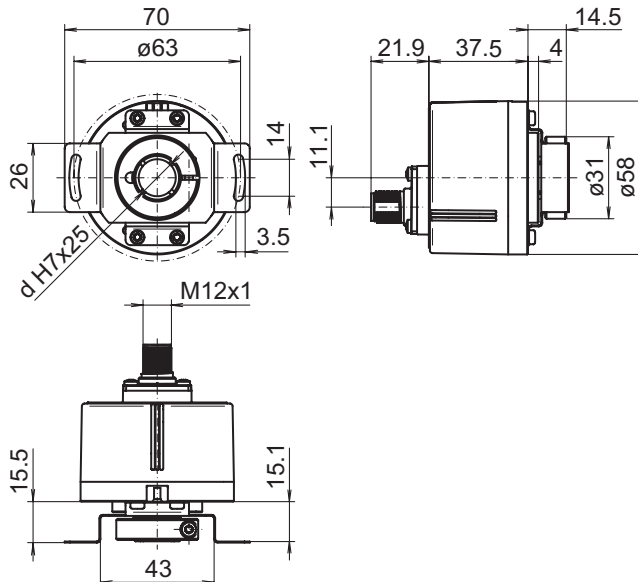

Clamping ring at A-side:
Through hollow shaft, flange connector M12 radial

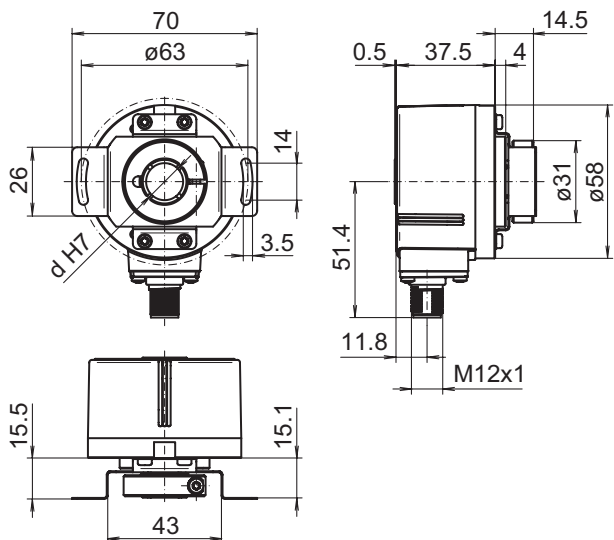

Clamping ring at A-side:
Blind hollow shaft, flange connector M23 radial

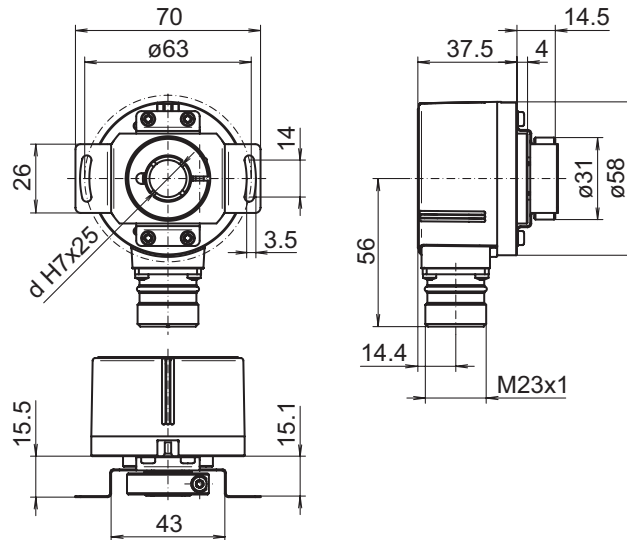

Incremental encoders

With blind or through hollow shaft

1...65536 pulses per revolution programmable

EIL580P - hollow shaft

Dimensions

Clamping ring at A-side:
Blind hollow shaft, flange connector M23 axial

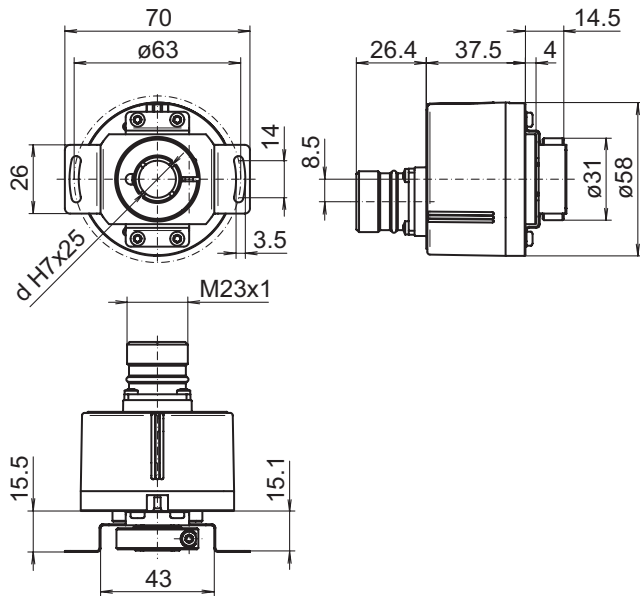

Clamping ring at A-side:
Through hollow shaft, flange connector M23 radial

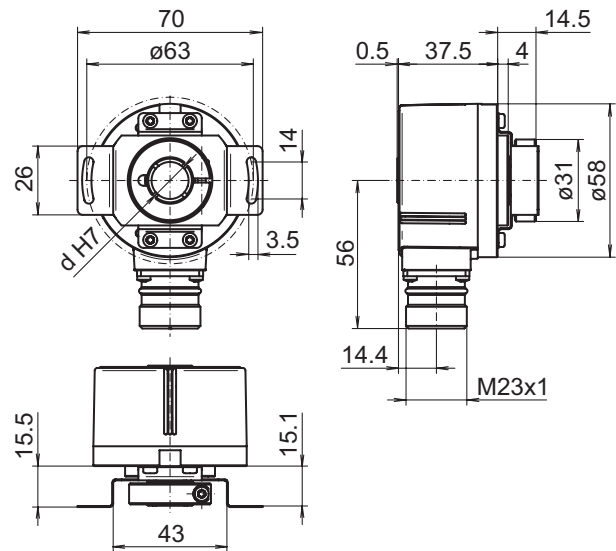

Clamping ring at A-side:
Blind hollow shaft, cable radial

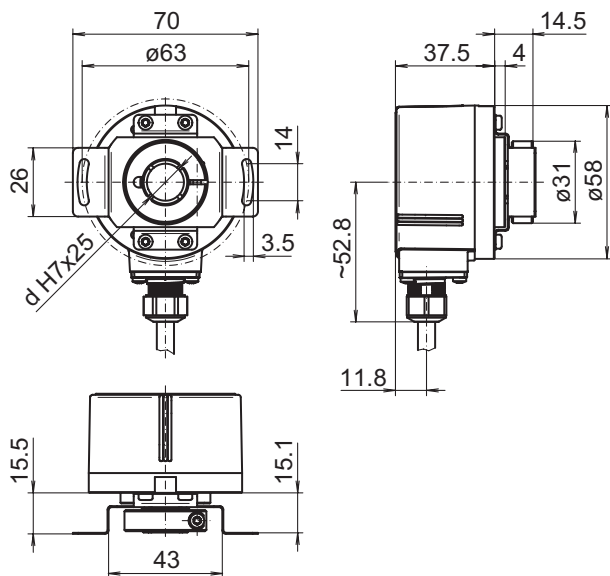

Clamping ring at A-side:
Blind hollow shaft, cable axial

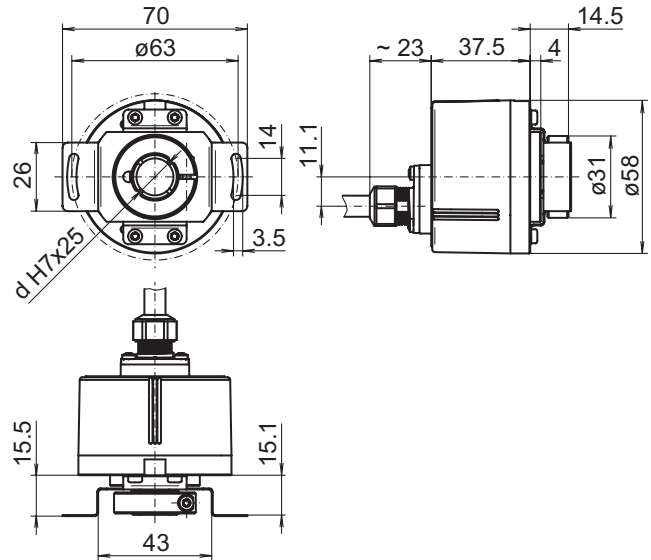

Incremental encoders

With blind or through hollow shaft
1...65536 pulses per revolution programmable

EIL580P - hollow shaft

Dimensions

Clamping ring at A-side:
Blind hollow shaft, cable tangential

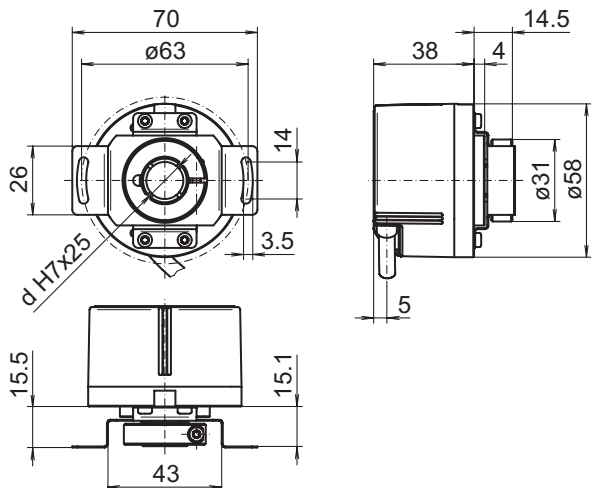

Clamping ring at A-side:
Through hollow shaft, cable radial

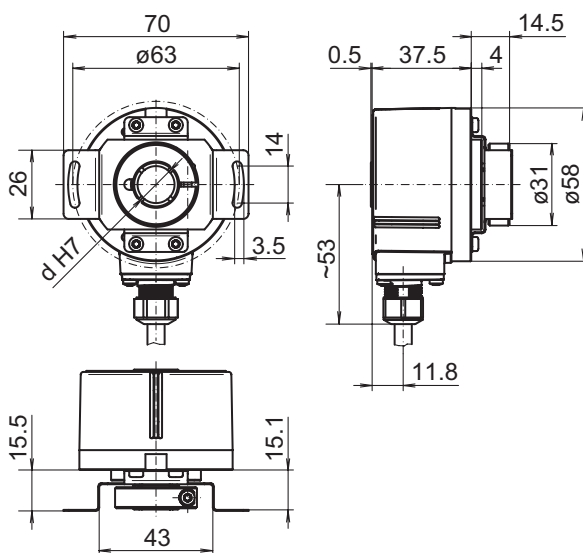

Clamping ring at A-side:
Through hollow shaft, cable tangential

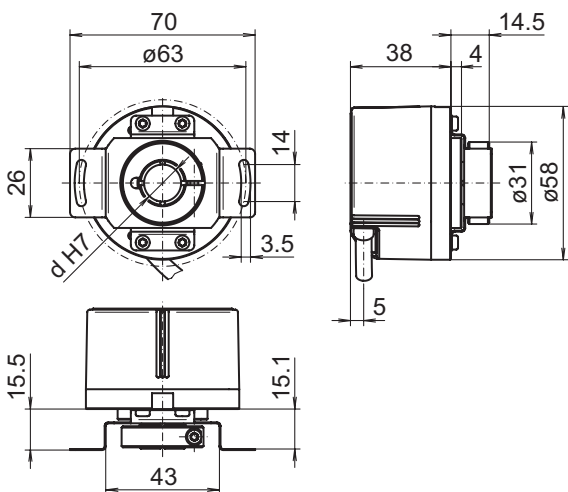

Clamping ring at B-side:
Through hollow shaft, flange connector M12 radial

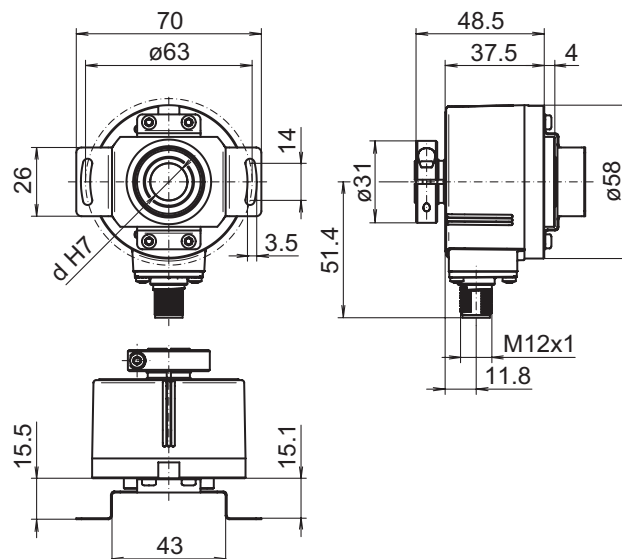

Incremental encoders

With blind or through hollow shaft

1...65536 pulses per revolution programmable

EIL580P - hollow shaft

Dimensions

Clamping ring at B-side:
Through hollow shaft, flange connector M23 radial

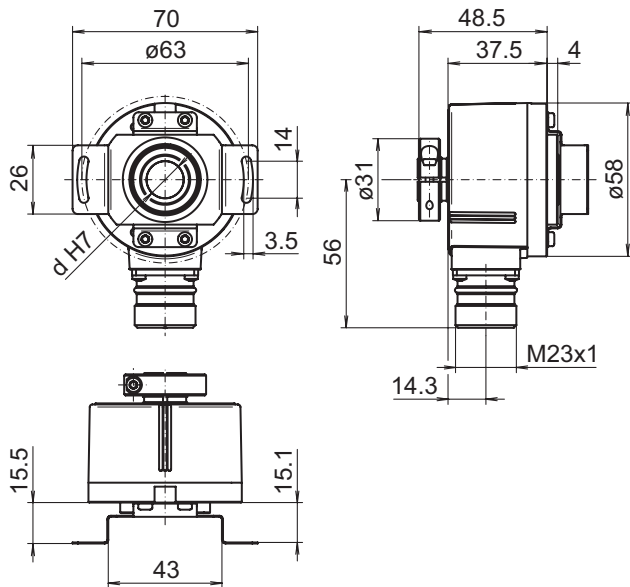

Clamping ring at B-side:
Through hollow shaft, cable radial

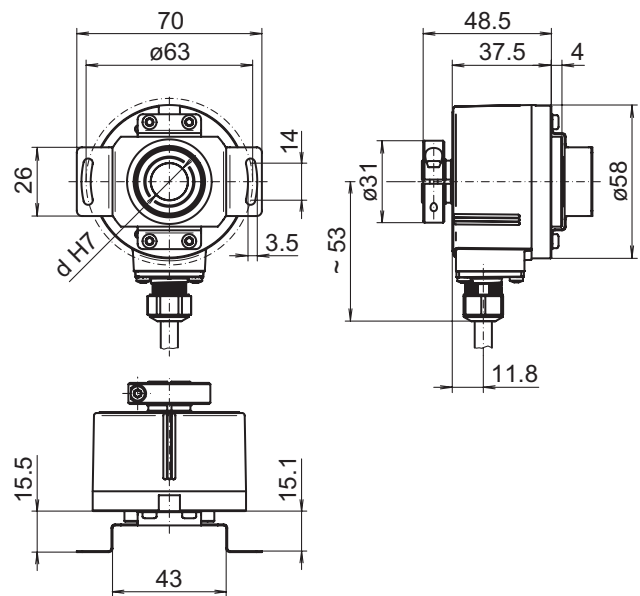

Pin torque support, axial, clamping ring at A-side

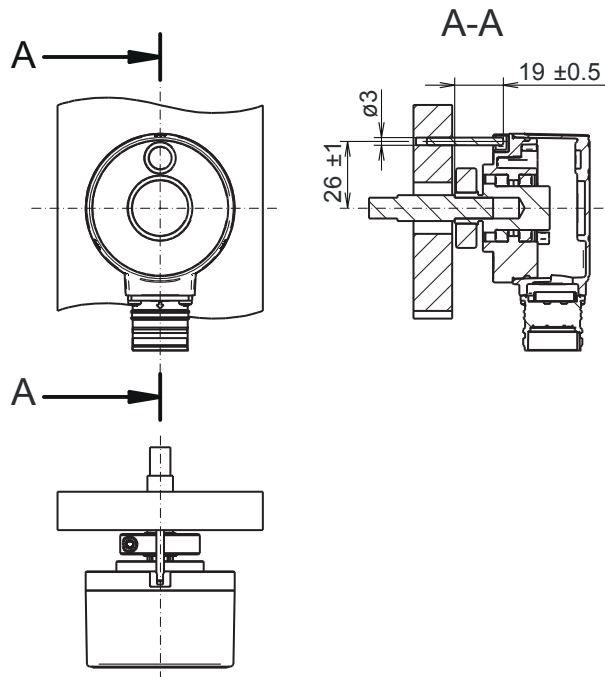

Pin torque support, radial

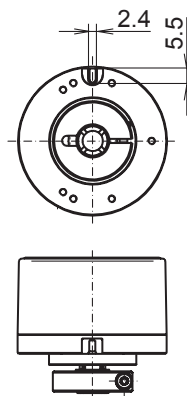

Incremental encoders

With blind or through hollow shaft
1...65536 pulses per revolution programmable

EIL580P - hollow shaft

Dimensions

Clamping ring at A-side: Through hollow shaft

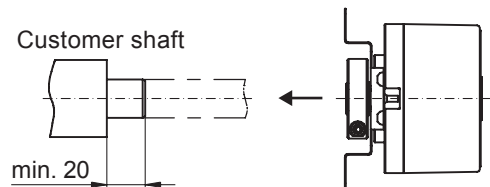

Clamping ring at B-side: Through hollow shaft

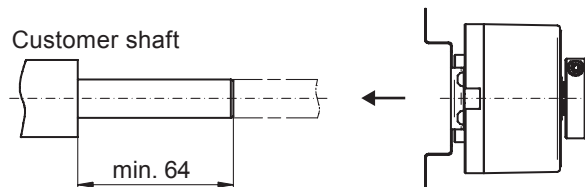

Blind hollow shaft

